

A nighttime photograph of a parking lot with several tall, modern streetlights illuminating the area. The scene is dark, with the lights creating a strong contrast and casting long shadows. The streetlights are arranged in a line, receding into the distance. The background shows a building and some trees.

# viewpoint

FAMILY PRODUCT SERIES

*Value Lighting with a  
Fresh Point of View*

# A Fresh Point of View

30'

25'

20'

15'

10'

5'

**VAL2**

32,000 - 46,000 Lumens

**VAM2**

24,000 - 31,000 Lumens

**VAS2**

16,000 - 23,000 Lumens

**VCS**

3,000 - 7,000 Lumens

**VCM**

9,000 - 14,000 Lumens

**VWM2**

8,000 - 14,000 Lumens

**VWS2**

3,000 - 5,000 Lumens

**VFM2**

7,000 - 11,000 Lumens

**VFS2**

2,000 - 5,000 Lumens

# CANOOPY

# WALL MOUNT

# FLOOD

# AREA



# viewpoint

## AREA LIGHT 2.0

Introducing Viewpoint 2.0, the ultimate 27 in 1 solution that simplifies every step of your lighting project. With field selectable lumen outputs, CCT options, and swappable optics all built into one sleek, durable design, it eliminates the need for countless SKUs while delivering unmatched flexibility. Engineered for parking, site, and perimeter applications, Viewpoint 2.0 combines precision performance, code ready controls, and quick install versatility, making it the smarter, faster, and more reliable choice for lighting professionals who demand results without compromise.

### THE ALL IN ONE SOLUTION

Field selectable CCT in 3K, 4K, or 5K and lumen selectability simplify planning and stocking. Plug and play NUROair Bluetooth mesh or field installable control receptacle devices for fast control setup or easily upgrade anytime. See back for more details.

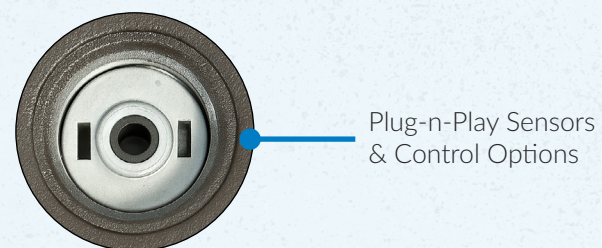
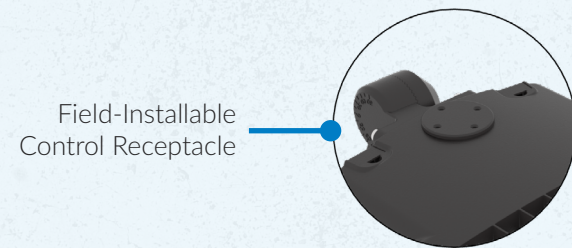
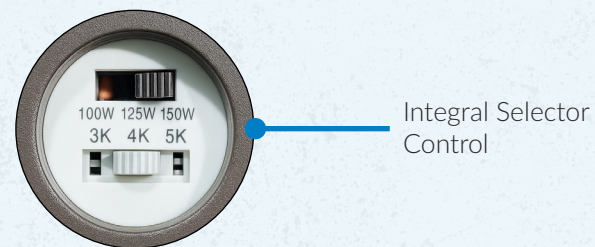

VAL2 Large  
VAM2 Medium  
VAS2 Small

Sizes	Lumen Range
VAS2	16L/20L/23L
VAM2	24L/28L/31L
VAL2	32L/38L/46L

### LIGHTING SIMPLIFIED

When the job demands fewer SKUs, faster installs, and uniform results, choose Viewpoint 2.0. Purpose built for parking, site, and perimeter with smart, code ready control options.

### 3 VERSATILE SIZES

Scale the same fixture across your site and standardize across sites, streamline stock, and deliver consistent light with IP66 toughness.

### OPTIC DISTRIBUTION FIELD SWAPPABLE LENS

Features 3 field-swappable IES optic distributions for application-specific flexibility

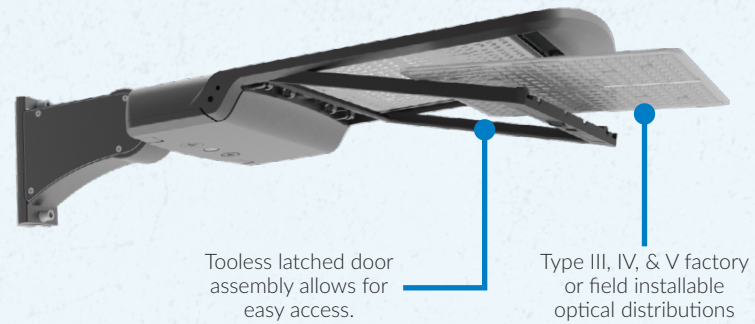

### PRECISION WITHOUT GLARE

The External Half Glare Shield reduces glare and directs light exactly where it is needed. Easy to install, it improves visual comfort and minimizes light pollution.

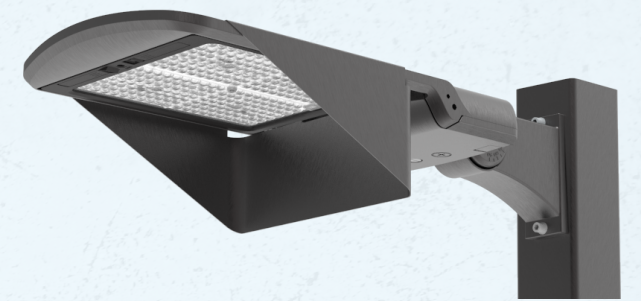

### CONTROL OPTIONS

From basic sensors to NUROair Bluetooth mesh, Viewpoint 2.0 fits your control strategy. Group fixtures, schedule runtimes, and set bi-level dimming across the site.



### ADJUSTABLE MOUNTING ACCESSORIES

Viewpoint comes standard with a fully adjustable universal round/square pole mount bracket, wall mount, or slipfitter

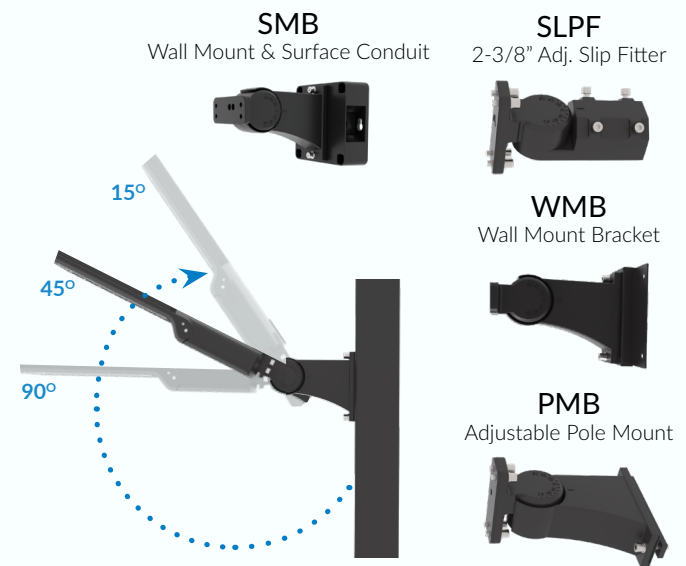

### PAIR WITH OTHER VIEWPOINT COMPANION PRODUCTS FOR A COHESIVE SITE

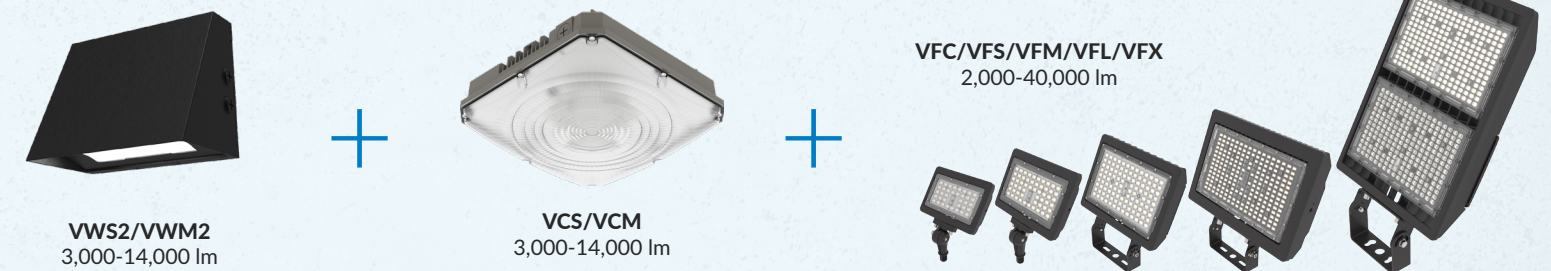

### SUITABLE APPLICATIONS

- Parking Lots
- Parking Structure
- Parks Education
- Hospitals
- Car Dealerships
- Shopping Centers
- Roadways



# viewpoint WALL PACK 2.0

## Distribution Selectivity for Precision Lighting and Photometric Control

The Viewpoint Wall Pack offers a minimalistic and clean aesthetic with industry leading technology advancements. With its slim wedge design, the Viewpoint Wall Pack packs a punch of illumination while remaining discrete and cost-effective. IES Distribution, Lumen, & CCT selectable, the Viewpoint Wall Pack luminaire offers a versatile, attractive and economical solution all while belonging to one cohesive product family for a cohesive site.

### DISTRIBUTION SELECTABILITY

The Viewpoint Wallpack 2.0 is designed to deliver targeted, efficient lighting. Its full cut-off profile eliminates uplight, helping protect night skies and reduce visual glare. A simple selector switch lets you choose among IES Type II, III, or IV distributions instantly, streamlining setup and product lead times.

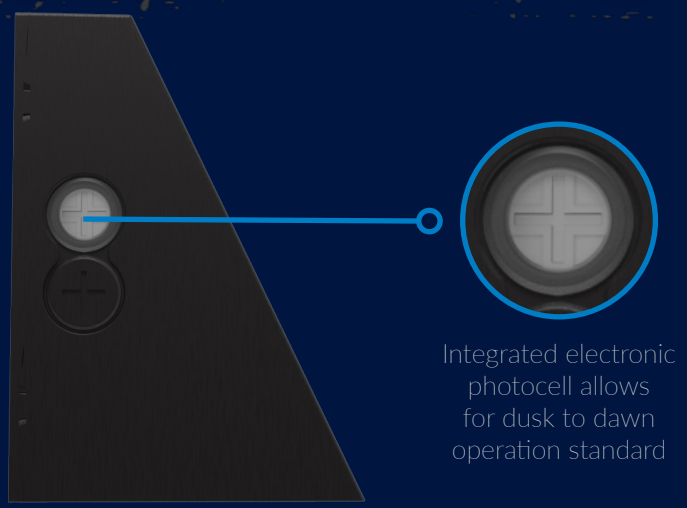
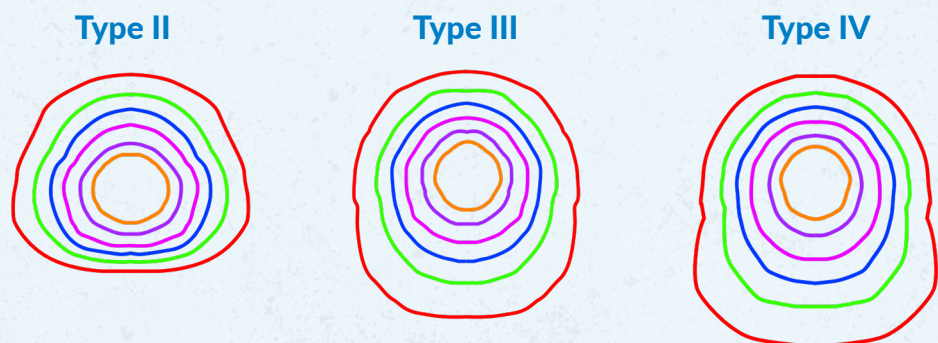

Integrated electronic photocell allows for dusk to dawn operation standard

- Provides uniform, full-cutoff illumination with electronic distribution selectable Type 2, Type 3, and Type 4 IES types to enhance site visibility while minimizing light pollution.
- Offers flexible customization with CCT and lumen selectable options, accommodating various lighting needs in a single fixture.
- Built-in Electronic photocell provides dusk to dawn illumination. Delivers reliable performance in harsh environments with IP65-rated, die-cast aluminum construction and a durable powder coat finish.

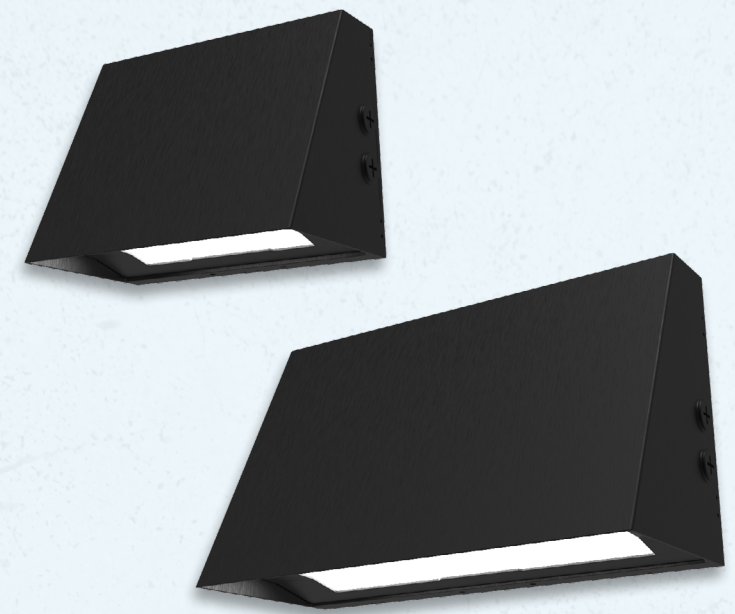

### TECHNICAL SPECIFICATIONS

- Architectural Wedge die-cast aluminum housing
- Bronze polyester powder coat finish (std.)
- Custom and factory select colors available
- Full Cutoff selectable Type 2, Type 3, and Type 4 distributions
- 3,000 - 14,000 Delivered Lumens with up to 148 LPW
- 3000K, 4000K & 5000K CCT Selectable via Integral selector
- Lumen Selectable - 3 lumen levels per SKU
- 0-10V Dim to off Driver with 12V Auxiliary for plug and play controls
- 4kV Surge Protection with optional 10kV & 20kV
- >80 Color Rendering Index (CRI)
- Calculated L70 >100,000 hrs @ 25°C per TM-21-19
- Operating Ambient Temperature: -40°C to +40°C (-40°F to 104°F)
- Bluetooth Programmable PIR Occupancy, Photocell, Grouping, Scheduling, & Bi-Level Dimming Sensors Available
- Battery backup & cold weather battery options available

### LUMEN & CCT SELECTABLE

The Viewpoint Wall Pack remains sleek yet versatile with the integral CCT and Lumen selectability. Ranging from 3,000 to 14,000 Lumens and CCTs from 3000K to 5000K, the Viewpoint Wall Pack is suited to fit any project needs.

### NUROAir CONTROLS

NUROAir Plug n Play Bluetooth Sensor is the ultimate groupable lighting control solution. With motion sensing, occupancy and vacancy detection, and photocell capabilities, it delivers unmatched flexibility to optimize ambiance and energy efficiency. The NUROAir App for iOS and Android makes setup simple so you can customize light levels, schedules, zones, and more directly from your phone or tablet. Manual control is also available with compatible wireless and wired wall switches.

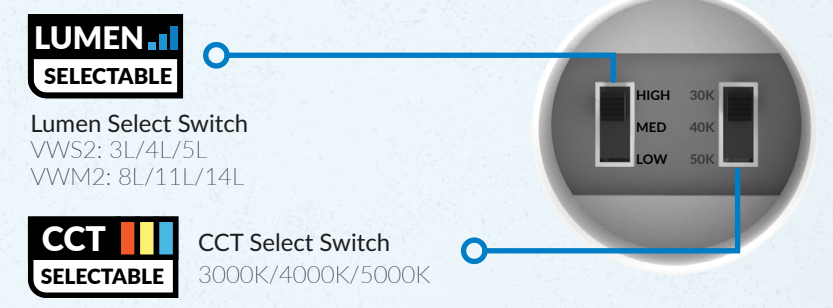

### QUICK MOUNT BRACKET

The Viewpoint Wall Pack 2.0 features a quick-mount bracket that streamlines installation without the need to open the luminaire. An integrated bubble level ensures precise alignment, while the no-drill rear housing delivers superior ingress protection and maintains the fixture's IP65 integrity in tough environments. The clean design offers no visible hardware for a clean refined appearance.

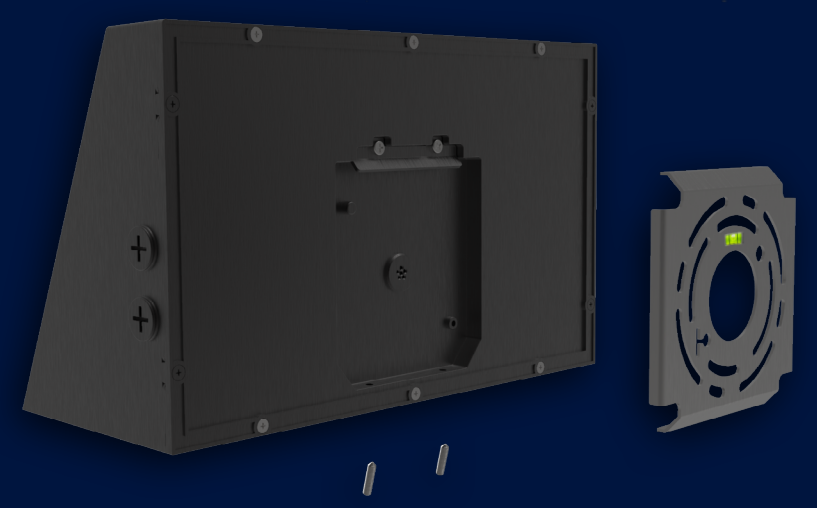

# viewpoint

## CANOPY & PARKING GARAGE

ILP's Viewpoint Canopy & Parking Garage luminaire combines sleek design, rugged durability and powerful performance capability to elevate outdoor lighting. Available in two compact sizes with lumen outputs ranging from 3,000 to 14,000 lumens, these fixtures feature a glare-reducing prismatic lens, switchable color temperatures (3000K/4000K/5000K), and multiple mounting options for easy retrofitting. With IP65 durability, smart control compatibility—including NUROAir wireless controls—and a 5-year standard warranty, the Viewpoint Canopy Series delivers reliable, high-performance lighting built to last.



### KEY FEATURES

- Available in two sizes & 6 lumen outputs from 3,000 - 14,000
- Diffuse prismatic lens that reduces glare and optimizes the delivered light for maximum visual comfort
- Effectively covers unsightly existing HID installation footprints with additional beauty plates available
- Controls ready with 12V Aux Dim To Off Drivers standard
- Switchable CCT (30K/40K/50K) offers warm, cool, and daylight in a single fixture with >80 CRI
- IP65 Rated Die Cast Aluminum Housings install by surface mount, junction box, or pendant mount

### LUMEN & CCT SELECTABLE

With field-selectable lumen outputs and color temperatures (3000K, 4000K, 5000K), the Viewpoint Canopy Series offers unmatched flexibility to customize light output and visual comfort.

#### LUMEN SELECTABLE

**Lumen Select Switch**  
VCS: 3L/5L/7L  
VCM: 9L/11L/14L

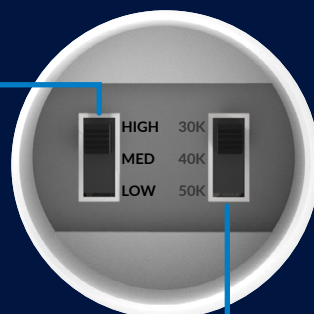

#### CCT SELECTABLE

**CCT Select Switch**  
3000K/4000K/5000K

### DISTRIBUTIONS

The standard Prismatic diffuse Medium Lens eliminates glare and optimizes the delivered light for visually comfortable illumination that creates a smooth, uniform distribution.

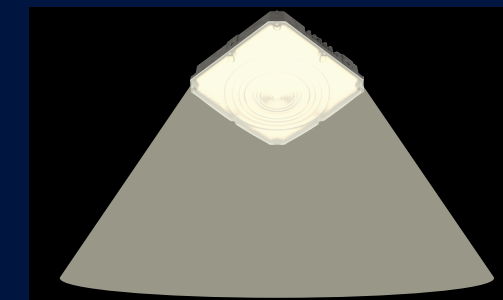
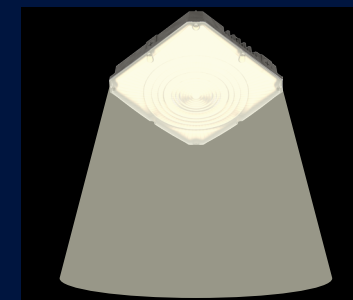

The Prismatic Wide Lens was designed specifically for parking garage applications to maximize fixture spacing and reduce fixture counts for the maximum return on investment.

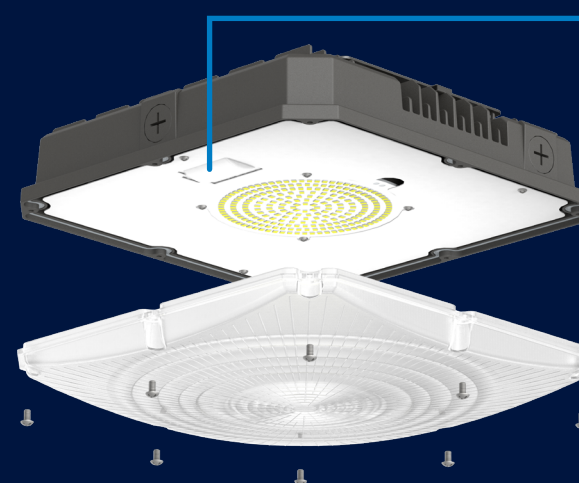

### MOTION DETECTION FEATURE

The optional MWS (Microwave Sensor) offers intelligent occupancy sensing to enhance energy savings and lighting efficiency. Factory-installed behind the lens for a clean, tamper-resistant appearance, the MWS detects motion through the fixture housing and adjusts light levels accordingly. This discreet sensor is ideal for applications requiring automated on/off or dimming control without compromising the fixture's sleek design.



### INNOVATIVE CONTROLS

The Viewpoint Canopy Series supports advanced control options, including motion sensors, photocells, emergency battery backup, and wireless systems like NUROAir. These smart features enhance energy savings, safety, and flexibility for a wide range of applications.



### MOUNTING

Installs via 3/4" conduit or quick surface mount bracket, eliminating the need to open the luminaire during installation, allowing for labor savings up to 50%.

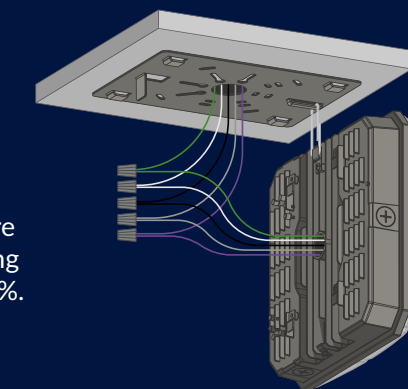

### INTEGRATED SIDE CAR EM AND REMOTE EM OPTIONS

Bright, efficient lighting with built-in reliability. Choose remote 9W-35W emergency backup or an integrated 9W sidecar solution to maintain illumination during outages. Operates on 120-277V down to 32°F and is Title 20 CEC compliant.

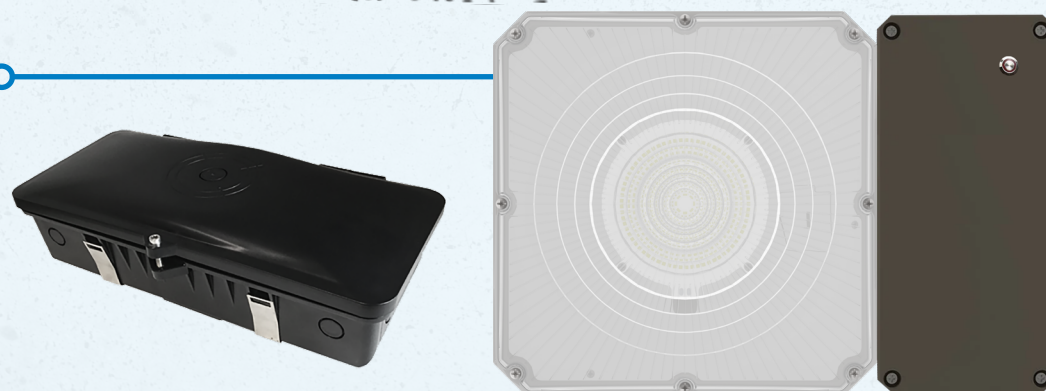

# viewpoint FLOODS 2.0

## The Floodlight That Adapts to Every Site.

With its sleek, low-profile design, the Viewpoint Flood Series discretely enhances and blends into site surroundings, while providing industry-leading features and performance. Upgrading your HID lights to the Viewpoint Flood Series allows for up to 85% energy savings, making it the clear choice for budget-friendly flood lights that meet demanding quality standards.

### KEY FEATURES

- Simplifies installation with a quick mounting options and consolidates SKUs with selectors for CCT, lumen output, distribution, and photocell in a single fixture.
- Provides field-selectable CCT at 3000K, 4000K, or 5000K to align with site requirements.
- Enables field-selectable lumen output to tune light levels per location while preserving a consistent site appearance and energy targets. Offers electronic distribution selection across three ANSI patterns to set the beam spread on site without swapping optics.
- Withstands tough environments with an IP65-rated die-cast aluminum housing and a sealed tempered glass lens with a durable bronze powder coat finish.

### EASY ACCESS SWITCHES

Easy-access switches simplify setup and reduce install time. They let you set key fixture options at the point of installation without opening the driver compartment or removing the luminaire. Use them to match output and performance to the space, reduce ordering complexity, and support consistent results across the site.

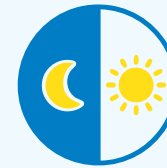

Switchable CCT (3K, 4K, 5K) and Integrated electronic photocell allows for dusk to dawn operation standard.

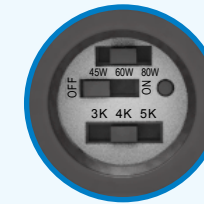

**CCT**  
SELECTABLE



Field-selectable distributions (5H5V, 6H6V, 7H6V) provide flexible beam control for diverse outdoor commercial sites.

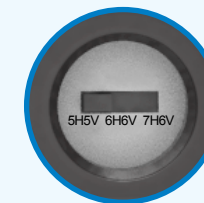

**DISTRIBUTION**  
SELECTABLE

### THREE LUMEN OUTPUTS

Lumen Selectability delivers three performance levels in one versatile fixture. Easily choose the ideal light output during installation to perfectly suit your space, no need to stock multiple models. Reduce SKUs, streamline ordering, and enjoy greater flexibility on every project.

**LUMEN**  
SELECTABLE

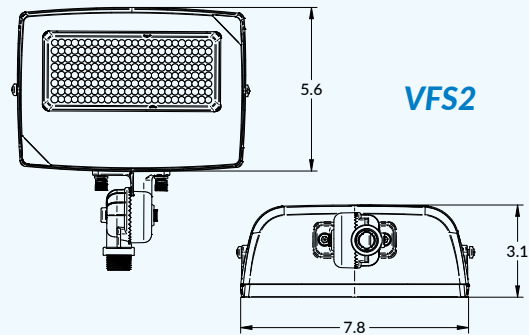

VFS2

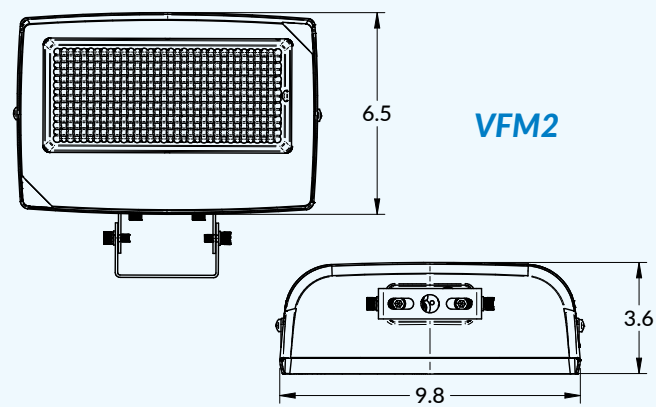

VFM2



VFM2  
7,000 - 11,000 Lumens



VFS2  
2,000 - 5,000 Lumens

### SHIELD

This visor reduces glare and spill light by shielding the LED source from high-angle view. It helps keep light on the target area and supports more comfortable sight lines for drivers, pedestrians, and nearby properties. Use it for perimeter lighting, building facades, walkways, and locations where backlight control matters. Field-installable and built to match the fixture finish and durability for outdoor use.



### SUITABLE APPLICATIONS

Landscape Wall Wash Spot & Flood Light Signage Elevation Illumination





# viewpoint

FAMILY PRODUCT SERIES



[ilp-inc.com](http://ilp-inc.com)