

# viewpoint

## CANOPY & PARKING GARAGE

ILP's Viewpoint Canopy & Parking Garage luminaire combines sleek design, rugged durability and powerful performance capability to elevate outdoor lighting. Available in two compact sizes with lumen outputs ranging from 3,000 to 14,000 lumens, these fixtures feature a glare-reducing prismatic lens, switchable color temperatures (3000K/4000K/5000K), and multiple mounting options for easy retrofitting. With IP65 durability, smart control compatibility—including NUROAir wireless controls—and a 5-year standard warranty, the Viewpoint Canopy Series delivers reliable, high-performance lighting built to last.



VCS

### KEY FEATURES

- Available in two sizes & 6 lumen outputs from 3,000 - 14,000
- Diffuse prismatic lens that reduces glare and optimizes the delivered light for maximum visual comfort
- Effectively covers unsightly existing HID installation footprints with additional beauty plates available
- Controls ready with 12V Aux Dim To Off Drivers standard
- Switchable CCT (30K/40K/50K) offers warm, cool, and daylight in a single fixture with >80 CRI
- IP65 Rated Die Cast Aluminum Housings install by surface mount, junction box, or pendant mount

### LUMEN & CCT SELECTABLE

With field-selectable lumen outputs and color temperatures (3000K, 4000K, 5000K), the Viewpoint Canopy Series offers unmatched flexibility to customize light output and visual comfort.

#### LUMEN SELECTABLE

Lumen Select Switch  
VCS: 3L/5L/7L  
VCM: 9L/11L/14L

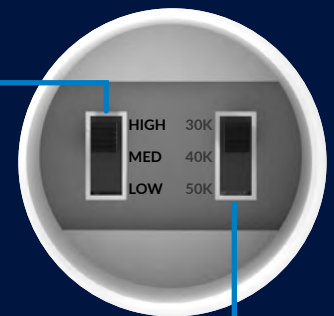

#### CCT SELECTABLE

CCT Select Switch  
3000K/4000K/5000K

### INTEGRATED SIDE CAR EM AND REMOTE EM OPTIONS

Bright, efficient lighting with built-in reliability. Choose remote 9W–35W emergency backup or an integrated 9W sidecar solution to maintain illumination during outages. Operates on 120–277V down to 32°F and is Title 20 CEC compliant.

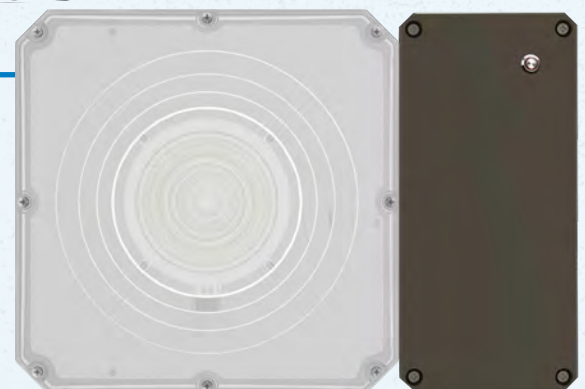

## DISTRIBUTIONS

The standard Prismatic diffuse Medium lens eliminates glare and optimizes the delivered light for visually comfortable illumination that creates a smooth, uniform distribution.

The Prismatic Wide Lens was designed specifically for parking garage applications to maximize fixture spacing and reduce fixture counts for the maximum return on investment.

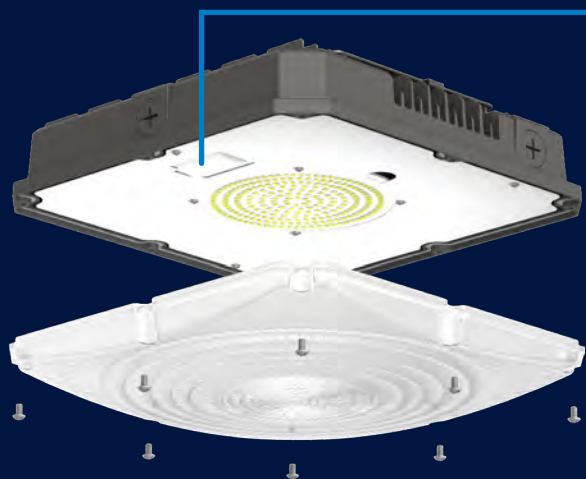

## MOTION DETECTION FEATURE

The optional MWS (Microwave Sensor) offers intelligent occupancy sensing to enhance energy savings and lighting efficiency. Factory-installed behind the lens for a clean, tamper-resistant appearance, the MWS detects motion through the fixture housing and adjusts light levels accordingly. This discreet sensor is ideal for applications requiring automated on/off or dimming control without compromising the fixture's sleek design.



## INNOVATIVE CONTROLS

The Viewpoint Canopy Series supports advanced control options, including motion sensors, photocells, emergency battery backup, and wireless systems like NUROAir. These smart features enhance energy savings, safety, and flexibility for a wide range of applications.

## MOUNTING

Installs via 3/4" conduit or quick surface mount bracket, eliminating the need to open the luminaire during installation, allowing for labor savings up to 50%.

